

Clanbro® POWER WASHER



PETROL POWER WASHER

MODEL NO: PLS220

PART NO: 7330347

OPERATION & MAINTENANCE INSTRUCTIONS

UK
CA | CE



ORIGINAL INSTRUCTIONS

DL0325 Rev 3

INTRODUCTION

Thank you for purchasing this CLARKE Petrol Power Washer.

Before attempting to use this product, please read this manual thoroughly and follow the instructions carefully. In doing so you will ensure the safety of yourself and that of others around you, and you can look forward to your purchase giving you long and satisfactory service.

GUARANTEE

This product is guaranteed against faulty manufacture for a period of 12 months from the date of purchase. Please keep your receipt which will be required as proof of purchase.

This guarantee is invalid if the product is found to have been abused or tampered with in any way, or not used for the purpose for which it was intended.

Faulty goods should be returned to their place of purchase, no product can be returned to us without prior permission.

This guarantee does not effect your statutory rights.

UNPACKING

Unpack your power washer and check to ensure the following items are present. Contact your CLARKE dealer immediately if any parts are missing or damaged.

| | |
|----------------------------------|-----------------------------|
| 1 x Petrol Power Washer | 1 x Inlet Thread Adaptor |
| 2 x Wheel/Tyre Assembly | 1 x Inlet Hose Adaptor |
| 2 x Wheel Axle c/w fixings | 1 x Water Inlet Filter |
| 1 x Gun Assembly | 1 x Rubber Foot c/w Fixings |
| 1 x Lance Assembly | 1 x Engine Manual |
| 1 x High Pressure Hose (Outlet) | 1 x Spark Plug Box Spanner |
| 1 x Water Hose (Inlet) | 1 x Tommy Bar |
| 1 x Chemical Inlet Hose & Filter | |









GENERAL SAFETY RULES



WARNING: WATER AT HIGH PRESSURE CAN BE DANGEROUS AND CAN CAUSE DAMAGE TO PERSONS OR PROPERTY IF THE OPERATOR IS CARELESS. NEVER ALLOW ANYONE TO OPERATE THIS EQUIPMENT UNLESS THEY ARE THOROUGHLY RELIABLE, AND FAMILIAR WITH THE SAFETY PRECAUTIONS.

1. **DO NOT** point the spray at other people, animals, electrical equipment or the machine itself.
2. **DO NOT** hold your finger over the high pressure nozzle.
3. **DO NOT** let children or untrained personnel use this machine.
4. **DO NOT** operate the machine with any of the covers removed.
5. **DO NOT** try to repair this machine. Always refer to your CLARKE service department for all repairs.
6. **DO NOT** supply any liquid other than water to the water inlet.
7. **DO NOT** use the detergent pickup facility to introduce flammable liquids/solvents, e.g. paint thinners, petrol, oil as there is a risk of explosion.
8. **ALWAYS** release the remaining pressure in the system; turn off the water supply and operate the trigger before you remove hoses or accessories.
9. **ALWAYS** keep the machine dry and away from the water spray.
10. **ALWAYS** use protective clothing and safety glasses. Loose particles and other items can be propelled at high speed by the water spray.
11. **ALWAYS** hold the gun securely & expect it to 'kick' when you pull the trigger.
12. **ALWAYS** respect the requirements of the local water company. Pressure washers may only be connected to the mains water supply if a system separator (also known as a backflow preventer) is installed in the supply hose.
13. **ALWAYS** disconnect from the water supply, and make sure that you drain the system when not in use. Keep in a cool dry location.
14. **ONLY** use detergents that are suitable for pressure washers, we recommend that you use CLARKE Traffic Film Remover or CLARKE Wash and Wax (available from your dealer).
15. **WARNING** High pressure water jets can be dangerous, the jet must not be directed at a person or anything that they are wearing.
16. **WARNING** High pressure hoses, fittings and couplings are important for the safety of the machine. Use only hoses, fittings and couplings recommended by the manufacturer.
17. **WARNING** Water that passes through a system separator (also known as a backflow preventer) is not safe to drink.
18. **DO NOT** use the pressure washer if there is damage to the inlet/outlet hose or the machine.

SAFETY SYMBOLS

| | |
|---|--|
|  | <p>ALWAYS: Read this manual and make sure that all warnings and instructions are clear before you use this pressure washer.</p> |
|  | <p>DANGER: Risk of fire or explosion. Stop the engine before you refuel the pressure washer. Keep flammable materials away from the work area. Do not spray flammable liquids.</p> |
|  | <p>DANGER: Risk to breathing. Engine exhaust fumes can kill. For outdoor use only. Work in a well ventilated area.</p> |
|  | <p>WARNING: Risk of injection or severe injury. DO NOT directly discharge stream at persons or animals. Keep clear of nozzle. This machine should only be used by qualified operators.</p> |
|  | <p>WARNING: Risk of spray injury. Spray can propel objects. Always wear ANSI approved Z87.1 Safety Glasses.</p> |
|  | <p>WARNING: Risk of chemical burn. NEVER spray acids, corrosive or toxic chemicals. Use only cleaners formulated for power washers.</p> |
|  | <p>WARNING: Risk of electrocution. Never direct the spray toward any electrical device or electrical outlet.</p> |
|  | <p>WARNING: Risk of unsafe operation. Keep children away from this equipment. Gun kicks back. Hold with both hands.</p> |
|  | <p>WARNING: Risk of hot surfaces. Avoid contact with hot engine exhaust components. Don't allow hoses to contact the engine muffler during or after use.</p> |

PRODUCT SPECIFICATIONS

| | |
|---|---|
| Model Number | PLS220 |
| Part Number | 7330347 |
| Engine Model & Type | G27F, Petrol Air Cooled |
| Engine Power & Capacity | 9HP, 6kW, 3600rpm, 270cc |
| Starting System | Recoil |
| Fuel Capacity (Maximum) | 6 Litre |
| Emissions (CO, HC+NOx, CO2) | 455.29, 6.92, 837.19 (g/kWh) |
| Max. Permissible Pressure | 240bar / 3481psi |
| Working Pressure (From Mains Supply) | 218bar / 3161psi |
| Working Pressure (From Barrel) | 218bar / 3161psi |
| Water Inlet Pressure Range | 3 - 6bar / 43 - 87psi |
| Max. Flow Rate (From Mains Supply) | 15L/min / 900L/hr |
| Working Flow Rate (From Mains Supply) | 15L/min / 900L/hr |
| Max. Flow Rate (From Barrel) | 13.5L/min / 810L/hr |
| Working Flow Rate (From Barrel) | 13.5L/min / 810L/hr |
| Water Type | Clean Cold Water |
| Ambient Operating Temperature | 40 ⁰ C (104 ⁰ F) |
| Input Water Temperature | 1 ⁰ C (34 ⁰ F) - 60 ⁰ C (140 ⁰ F) |
| Water Supply Hose Diameter | Suitable Snap Connector - 1/2" or 3/4" Hose |
| Water Supply Suction Depth | Less Than 1m |
| Detergent Hose Length | 1.5m |
| High Pressure Hose Length | 10m |
| Sound Pressure Level (L _{PA}) | 79.54dB |
| Sound Power level (L _{WA}) | 93.35dB |
| Guaranteed sound power level (L _{WA}) | 94dB |
| Sound Uncertainty Factor K | 0.59dB |
| Vibration (Main Handle/Support Handle) | 1.829m/s ² /1.562m/s ² |
| Uncertainty Factor | 1.5m/s ² |
| Max. Dimensions (L x W x H) | 799mm x 684mm x 955mm |
| Weight | 54.8kg |

OVERVIEW

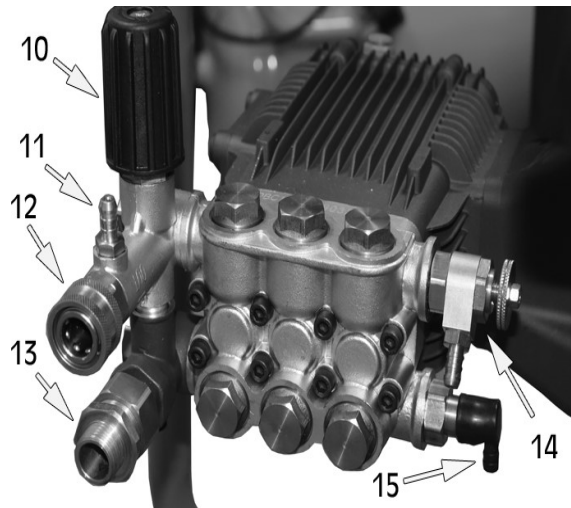
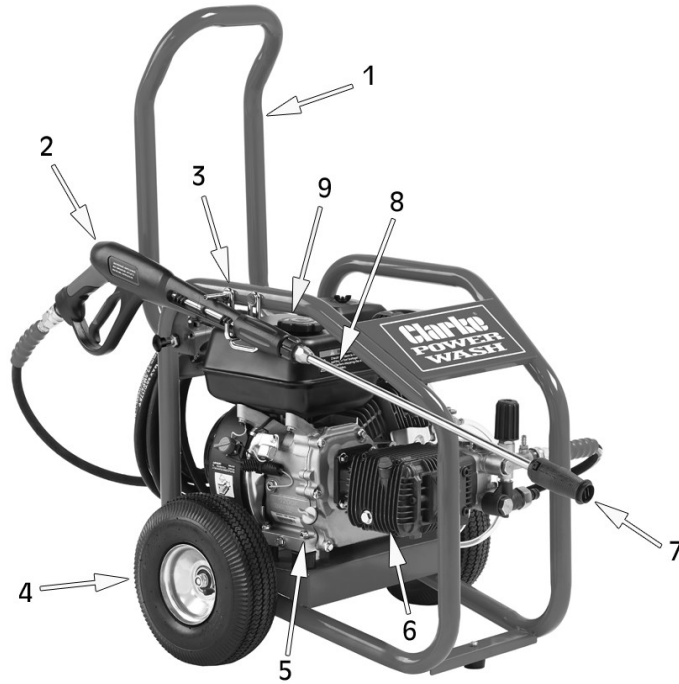

OVERVIEW DESCRIPTIONS

| NO | DESCRIPTION | NO | DESCRIPTION |
|-----------|--------------------|-----------|------------------------------|
| 1 | Foldable Handle | 10 | Pressure Regulator |
| 2 | Gun | 11 | Chemical Detergent Inlet |
| 3 | Wand/Lance Bracket | 12 | Water Outlet |
| 4 | Wheels | 13 | Water Inlet |
| 5 | Engine | 14 | Suction Valve |
| 6 | Pump | 15 | Thermal Relief Valve |
| 7 | Adjustable Nozzle | 16 | High Pressure Hose |
| 8 | Spray Wand/Lance | 17 | Water Inlet Hose with Filter |
| 9 | Petrol Tank | 18 | Detergent Hose |

ASSEMBLY

FITTING THE WHEELS

1. Insert the axle as shown.
 - Rotate the axle so that the spring loaded pin pops through the hole on the frame.
2. Fit the wheels to the axles and secure with the locking nut supplied.

NOTE: DO NOT overtighten the nuts, the wheels must be able to rotate freely.

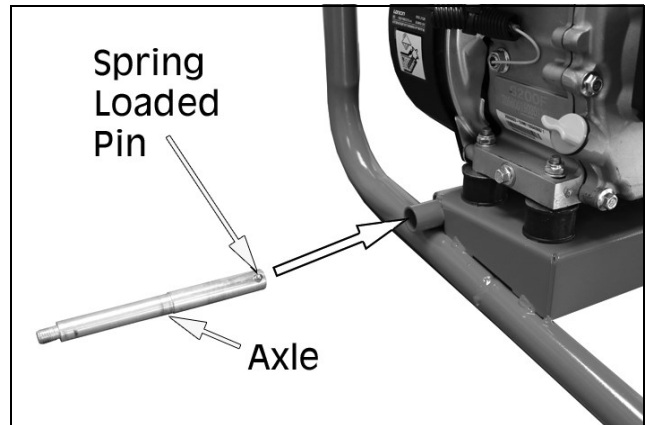

FITTING THE RUBBER FOOT

1. Fit the rubber foot as shown.
 - Secure with the nut and spring washer supplied.

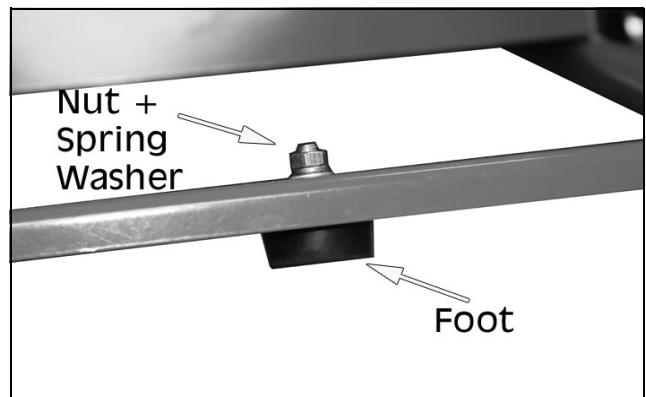

ASSEMBLE THE LANCE

1. Connect the spray wand to the lance and tighten securely.

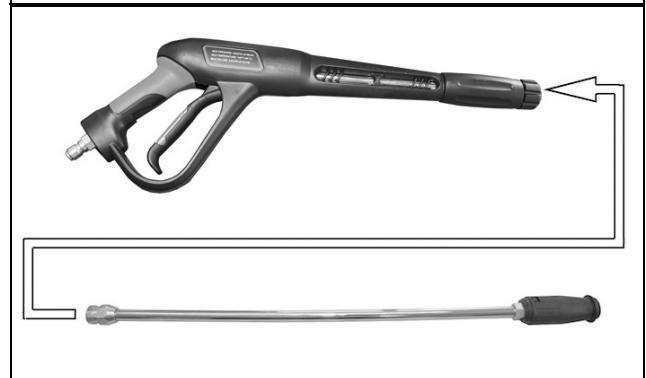

FOLDING HANDLE

1. Lift the handle into the raised open position.
2. Secure in place using the handle locking knobs shown.

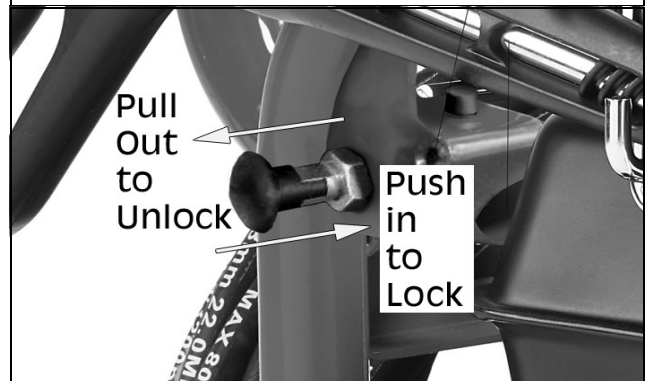

THE HIGH PRESSURE HOSE

CONNECT THE HOSE TO THE GUN

1. Slide the connector on the hose backwards.
2. Push the gun into the connector.
3. Release the connector.

NOTE: Make sure the connection is secure.

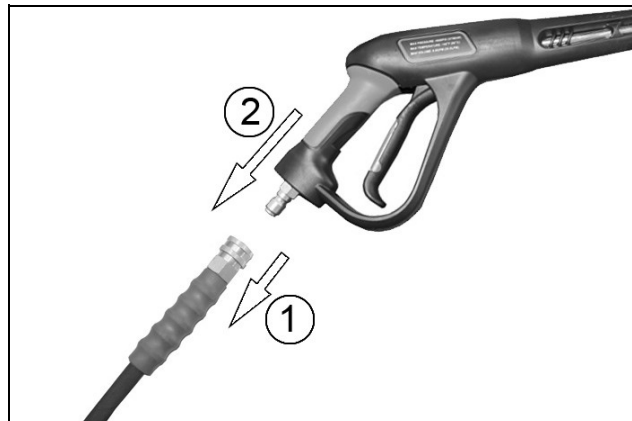

CONNECT THE HOSE TO THE POWER WASHER

1. Slide the connector on the power washer towards the machine.
2. Push the hose into the connector.
3. Release the connector.

NOTE: Make sure the connection is secure.

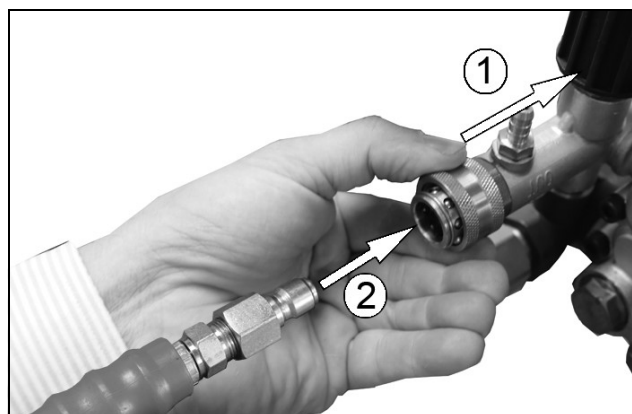

CONNECT WATER INLET HOSE

1. Remove the travel cap if fitted.
2. Fit the hose adaptor as shown.
3. Connect the water supply hose to the hose adaptor.

NOTE: The water source must provide a minimum of 25 litres per minute @ 20 PSI.

NOTE: Make sure the water inlet hose is screwed on tightly.

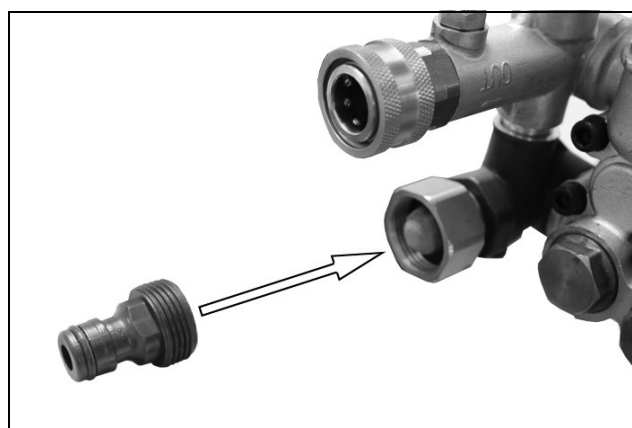

LANCE STORAGE BRACKET

1. Fit the bracket into the position shown and secure using the washers and nuts supplied.



HOSE STORAGE BRACKET

1. Screw a nut and washer onto each leg of the hose bracket as shown.

NOTE: You will need 4 x nuts & washers. 2 sets for securing on the top and 2 sets for securing on the bottom.

2. Fit the hose bracket in place on the rear of the washer as shown and secure from underneath using a nut and washer.

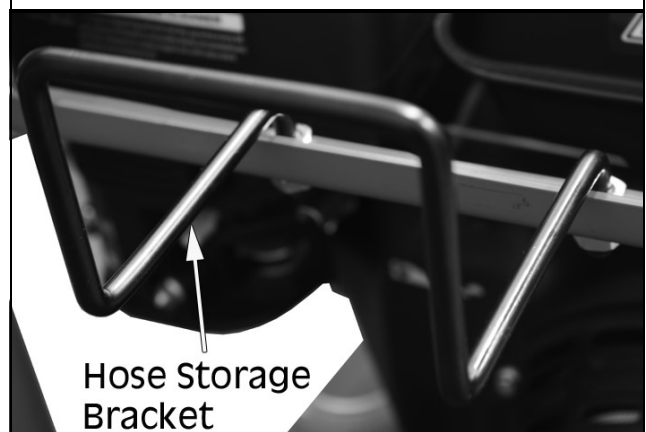
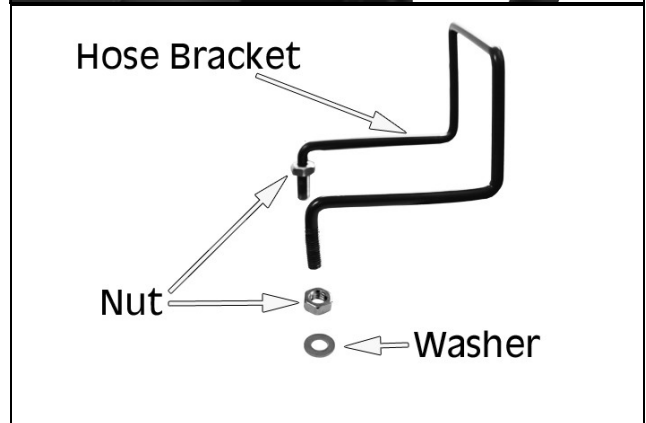

REMOVE THE TRAVEL PLUG BEFORE USE.

1. Use a 17mm spanner to remove the red travel plug.
2. Inside the small bag attached is an oil breather plug which needs to be fitted in its place.
 - The oil breather plug must only be inserted hand tight.



BEFORE USE



WARNING: TO CARRY OUT THIS CHECK, PLACE THE POWER WASHER ON LEVEL GROUND WITH THE ENGINE SWITCHED OFF.

WARNING: TAKE CARE NOT TO TOUCH ANY HOT PARTS OF THE POWER WASHER WHEN CHECKING THE OIL LEVELS.

IMPORTANT: The engine is supplied without any oil in it and must be filled to the correct level before use, see below.

CHECKING THE PUMP OIL LEVEL

1. Look at the sight glass on the pump to check the oil level inside.
 - The oil should be half way up the sight glass.
2. If required, top up with oil. See Changing the Pump Oil on page 19.
 - We recommend the use of 10W-
SAE30 oil in this pump.

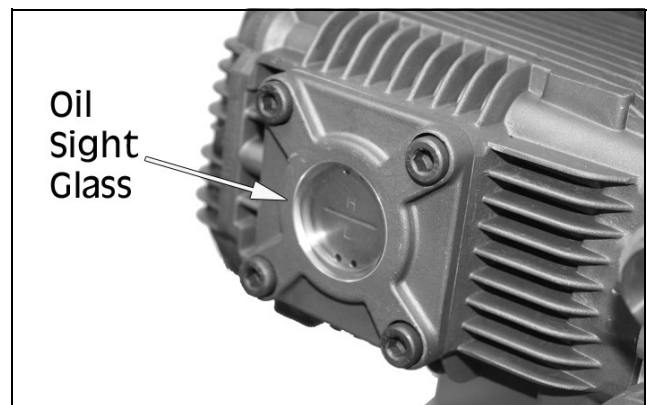

CHECKING THE ENGINE OIL LEVEL



WARNING: RUNNING THE ENGINE WITH INSUFFICIENT OIL WILL CAUSE ENGINE DAMAGE.

1. Turn the oil filler cap/dipstick anti-clockwise and remove it from the oil filler tube.
2. Wipe the oil filler cap/dipstick with a clean cloth.
3. Insert the oil filler cap/dipstick back into the oil filler tube and then remove it again. Do not screw it in when doing this.

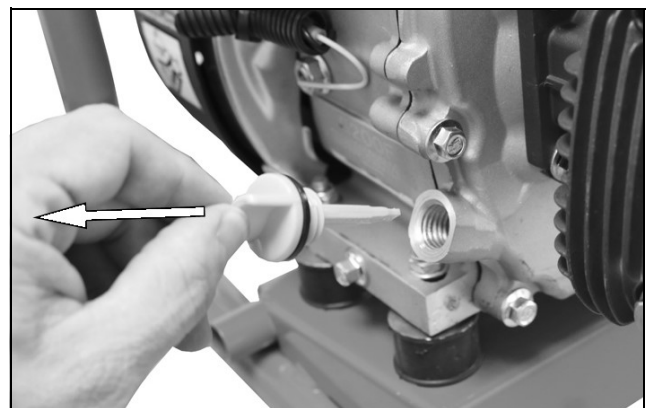

4. If the oil is low, fill the oil reservoir to the edge of the oil filler hole.
 - We recommend the use of 10W-
SAE30 oil in the engine.
5. Replace the oil filler cap.

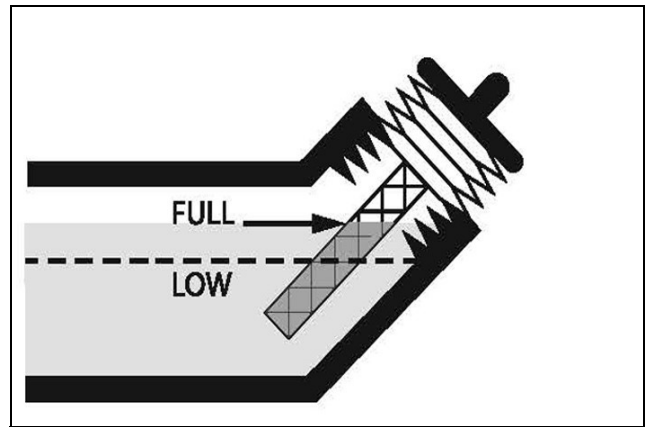

CHECKING THE FUEL LEVEL



WARNING: ALWAYS REFUEL IN A WELL VENTILATED AREA AWAY FROM ANY SOURCES OF IGNITION AND HEAT.

WARNING: ALLOW THE UNIT TO COOL DOWN BEFORE REFUELLING.

WARNING: DO NOT LEAVE FUEL WITHIN THE REACH OF CHILDREN.

1. To check the fuel level, remove the fuel tank cap.
2. Just inside the fuel tank is a fuel strainer. Check this filter periodically and remove any contaminants which may have accumulated.
3. Refuel in a well-ventilated area before starting the engine. If the engine has been running, allow it to cool. Refuel carefully to avoid spilling fuel. Do not fill above the fuel strainer shoulder.
4. After refueling, replace the fuel filler cap securely.

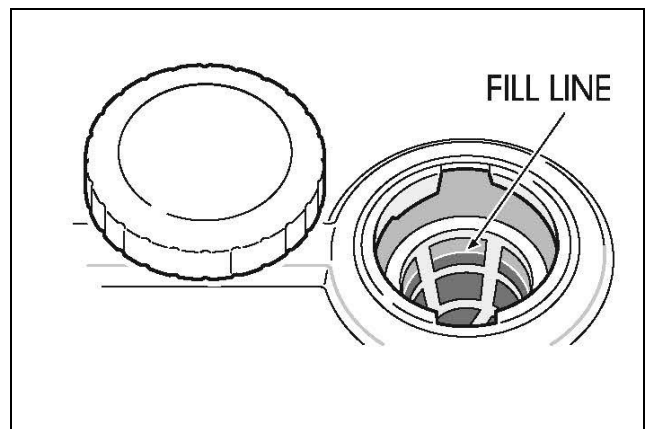

RECOMMENDED FUEL

Use unleaded petrol with an octane rating of 86 or higher. Do not overfill.

PRESSURE REGULATOR

When purchased, the pressure regulator may be set to minimum.

Turn the pressure regulator on the pump fully clockwise to allow water pressure to increase when the pressure washer is running.

If you find the pressure is too high, you can adjust this later by turning the regulator anti-clockwise.

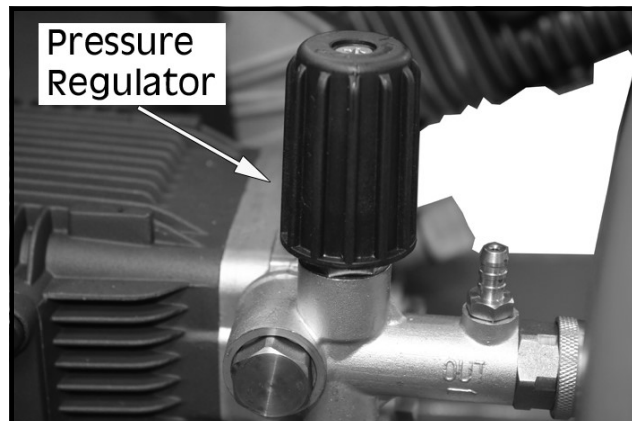

SAFETY FEATURES

Bypass mode: In bypass mode, the pump recirculates the water because the trigger of the spray gun is not being pulled. If the unit is left in bypass mode for more than two minutes, the water temperature will rise to a dangerous level and could damage internal components of the pump.

NOTE: Any damage to the pump due to these causes will not be covered under warranty.

Thermal Relief Valve: In an effort to prevent damage, pumps are equipped with a thermal relief valve. This valve will open when the temperature inside the pump becomes too high. The valve will then release a gush of water in an effort to lower the temperature inside the pump. Immediately after this occurs, the valve will close.



STARTING YOUR POWER WASHER



WARNING: FAILURE TO TURN ON THE WATER COULD CAUSE DAMAGE TO THE PUMP.

Prior to starting, refer to your engine manual for proper starting procedures for your engine type.

1. Make sure the engine has sufficient fuel. See page 12.
2. Check the engine oil level. See page 11.

3. Turn water supply on.
4. Set the engine switch to 'ON'.

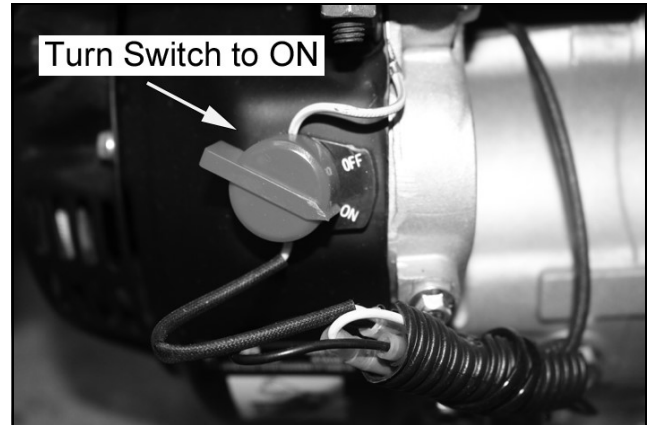

5. Set the fuel valve lever to the 'on' position.

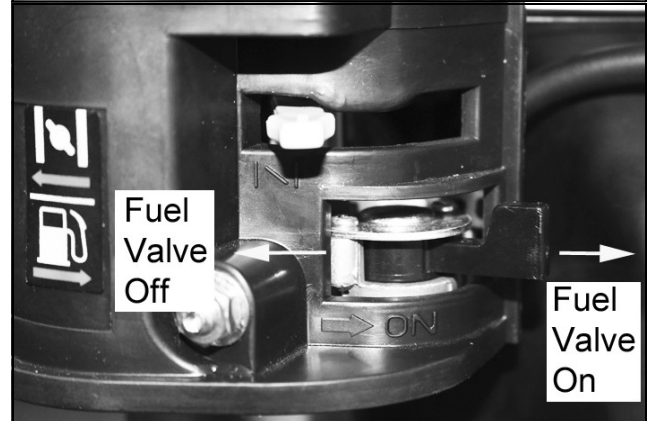

6. If you are starting the power washer 'cold' set the choke lever to the CHOKE position (left). If the power washer is warm skip this step.

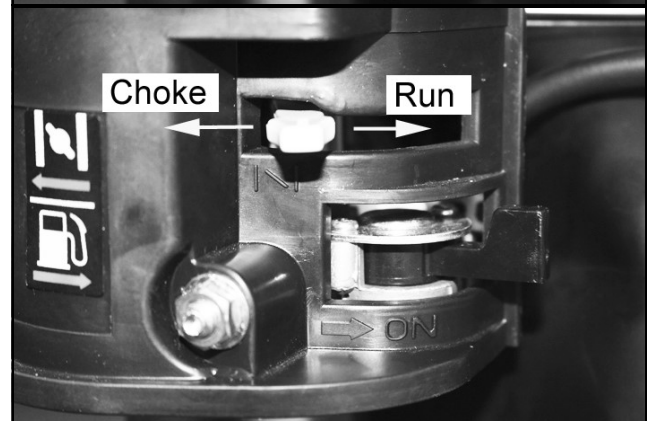

7. Set the throttle to the 1/3rd of the way towards the fast setting.

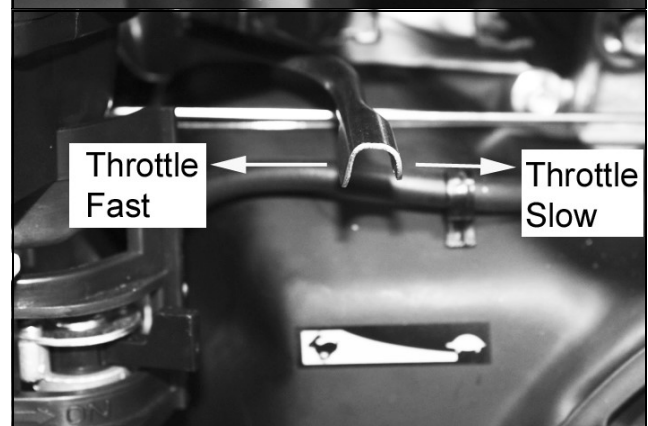

- Pull the starting handle lightly until you start to feel resistance and then pull up sharply to start the power washer.

NOTE: You may have to do this more than once.



WARNING: ONCE THE POWER WASHER HAS STARTED, RELEASE THE STARTING HANDLE SLOWLY TO AVOID INJURY/DAMAGE AS IT WHIPS BACK.

- Once the engine has warmed up, set the choke lever to the 'RUN' (right) position.

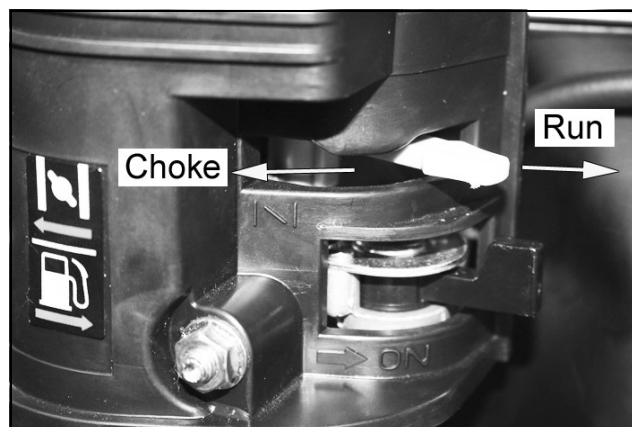

USING THE POWER WASHER

- Pull the trigger on the gun to start water flow.
 - Stand on a stable surface and grip the gun/spray wand firmly with both hands.
 - Expect the gun to kick when the trigger is pulled.
- Release the trigger to stop water flow.

NOTE: The power washer will automatically go into bypass mode, In bypass mode, the pump recirculates the water because the trigger of the spray gun is not being pulled. If unit is left in bypass mode for more than two

minutes, the water temperature will rise to a dangerous level and could damage internal components of the pump.



WARNING: DO NOT ALLOW THE UNIT TO OPERATE IN BYPASS MODE FOR MORE THAN TWO MINUTES AT ANY TIME.

ADJUSTING THE SPRAY

The nozzle is adjustable to allow you to change the spray from a narrow jet of water to a wide spray.

To adjust the nozzle, proceed as follows.

1. Hold the shaft of the spray wand in one hand.
2. Twist the nozzle with the other hand.
3. To vary the spray between narrow and wide, turn the nozzle counter-clockwise through a half-of-a-turn.
 - Slide the nozzle forward for low pressure and backwards for high pressure.

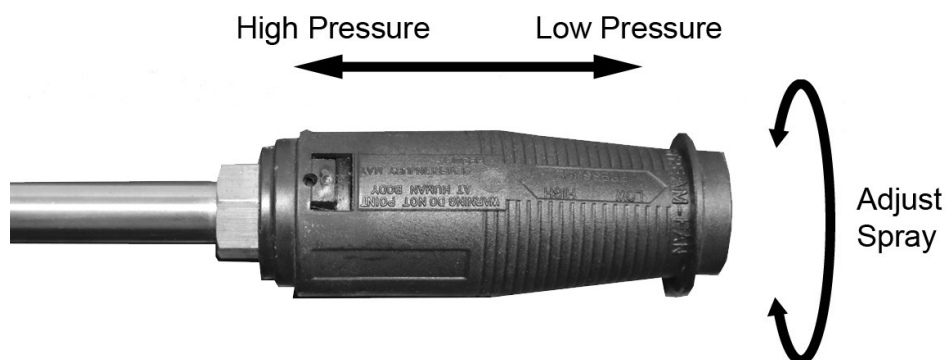

ADJUSTING THE PRESSURE

There are 4 ways to adjust the pressure.

1. Adjust the pressure regulator on the pump. Turn the pressure regulator knob counter clockwise to lower pressure. Once you have finished using your power washer, return the pressure regulator to its original position.
2. Back away from the surface to be cleaned. The further away you are, the less the pressure will be on the surface being cleaned.

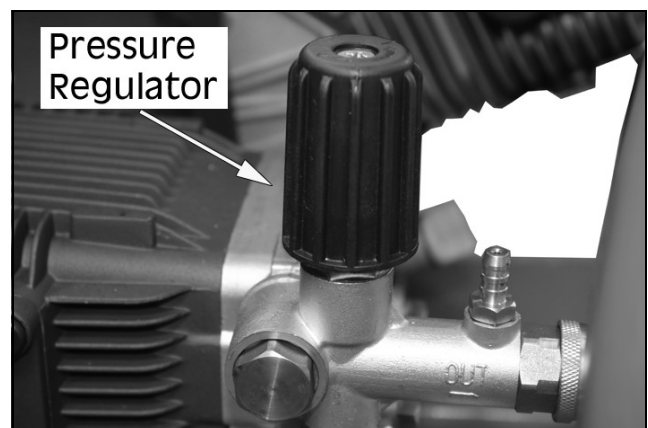

3. Reduce the speed of the engine (RPM). Slow the engine down and the water pressure will also go down.
4. Adjust the spray to a wider angle.
 - Slide the nozzle forward for low pressure and backwards for high pressure.

APPLYING DETERGENTS AND CLEANING SOLVENTS

1. Push the detergent hose onto the ribbed fitting as shown.
2. Place the other end of the detergent hose with the filter on it, into a container holding the chemical/cleaning solution.
3. Slide the nozzle forward for low pressure operation.

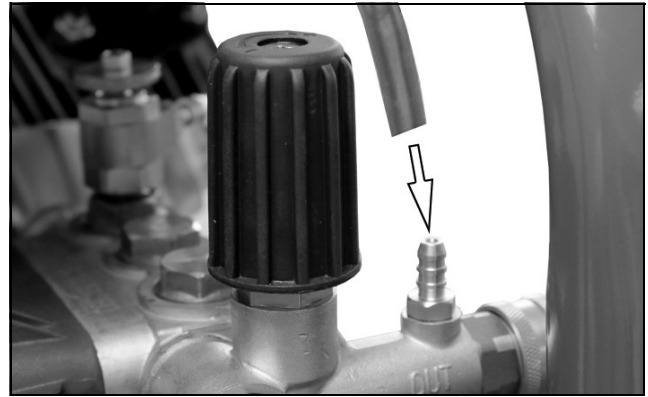

NOTE: See page 20 for detergent and cleaning products available from your CLARKE dealer.

SHUTTING DOWN

1. After each use, if you have applied detergents, place the detergent hose into a container of clean water and run clean water through the detergent injection system to flush the system thoroughly.

NOTE: Failure to do so could cause damage to the pump.

2. Set the engine switch to 'OFF'.

NOTE: NEVER turn the water off with the engine running.

3. Turn the water supply off.
4. Pull the trigger on the spray gun to relieve any water pressure.
5. See storage section in this manual for proper storage procedures.

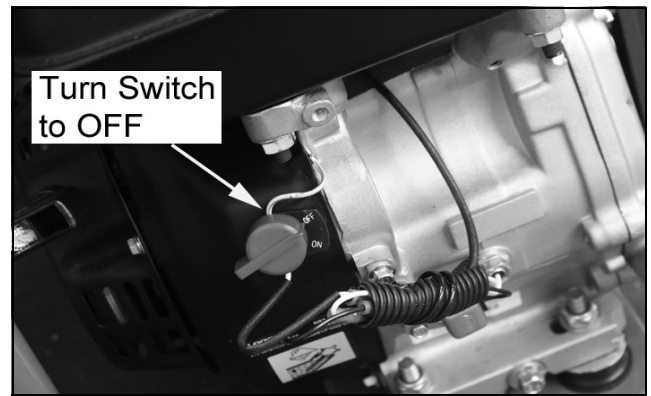

WATER BUTT CONNECTION

This machine has the ability to draw its own water, meaning you can use water not under pressure, such as rainwater collected in a water butt. To do this you must carry out the following procedure.

1. Attach the filter to the end of the pipe supplied.
2. Place the filter into the water butt.

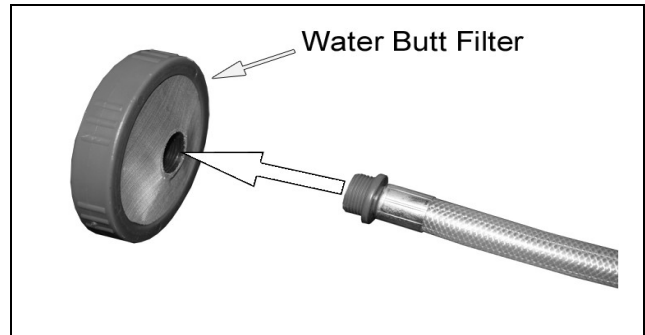

3. Remove the hose adaptor and replace it with the inlet connector supplied.

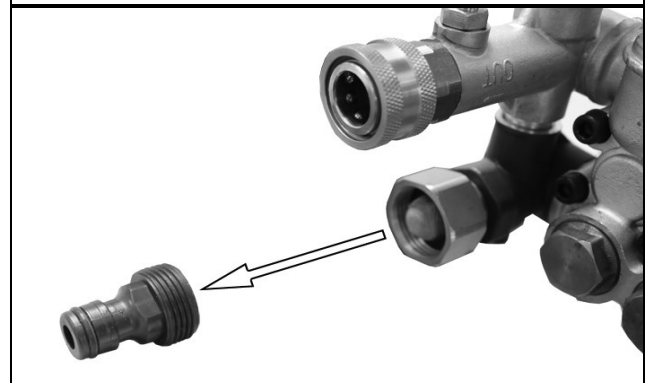

4. Connect the pick-up pipe to the pressure washer as shown.
 - Tighten securely

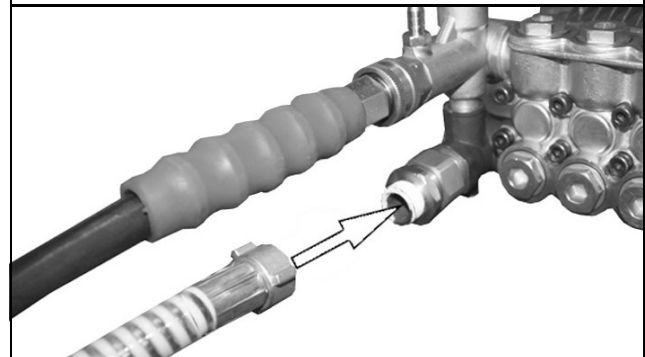

5. Twist open the suction valve shown.
6. Start the power washer. See Starting your Power Washer on page 13.
 - Water is ejected from the nozzle.
7. When the water spray being ejected is consistent and at high pressure, close the suction valve.
8. Use the pressure washer as normal.

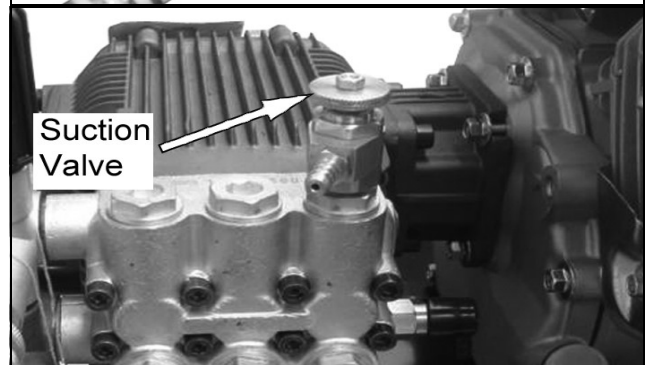

NOTE: DO NOT let the pressure washer run dry.

MAINTENANCE

CHANGING THE PUMP OIL



CAUTION: PROLONGED EXPOSURE TO USED OIL IS DANGEROUS, ALWAYS WASH YOUR HANDS THOROUGHLY AFTER HANDLING USED OIL.

1. Unscrew and remove the oil filler cap.
2. Place an oil collection tray (not supplied) under the drain plug.
3. Unscrew the drain plug, and allow the used oil to drain from the crankcase into the oil collection tray.

NOTE: Drain the oil when the engine is warm, this will ensure the oil flows out quicker.

4. Replace the drain plug and its ring seal.
5. With the power washer in a level position, fill to the centre of the sight-glass with the recommended oil.
6. Replace the oil filler cap.

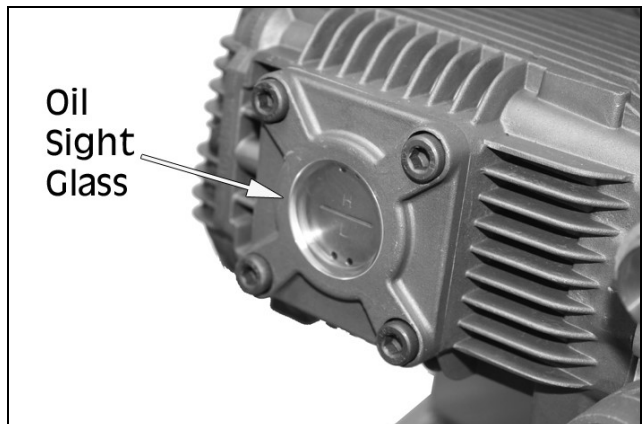
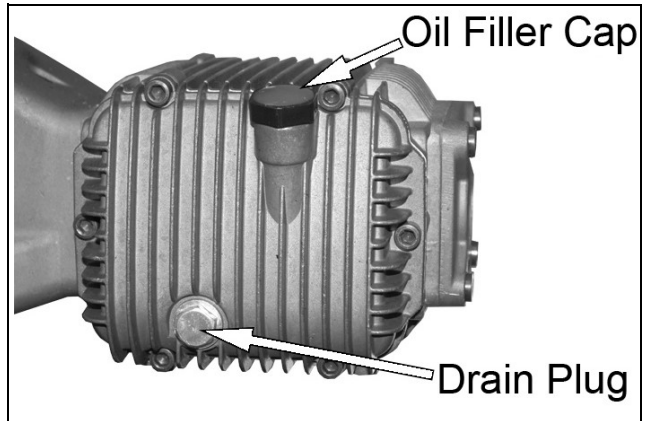

ENVIRONMENTAL PROTECTION

One of the most damaging sources of pollution is oil. **DO NOT** throw away used oil with your domestic rubbish or down drains and sinks. Place it in a leak proof container and take it to you local waste disposal site.

CLEANING THE NOZZLE

If the nozzle becomes partially clogged or restricted by dirt or other foreign material, excess pump pressure may develop. Clean the nozzle immediately by following the instructions below.

1. Shut off the power washer and turn off the water supply.
2. Pull the trigger on the gun handle to relieve any water pressure.
3. Disconnect the lance from the gun.
4. Remove any obstructions and back flush with clean water.
5. Direct the water supply into the spray wand end for 30 seconds to back flush loosened particles.
6. Reconnect the spray wand to the gun and turn on the water supply.

CLEANING THE WATER INLET

The water filter should be checked regularly and cleaned if necessary.

1. Remove any fittings to the water inlet.
2. Remove the water filter from the water inlet.
3. Clean the filter by flushing it with water on both sides
4. Replace the water filter.

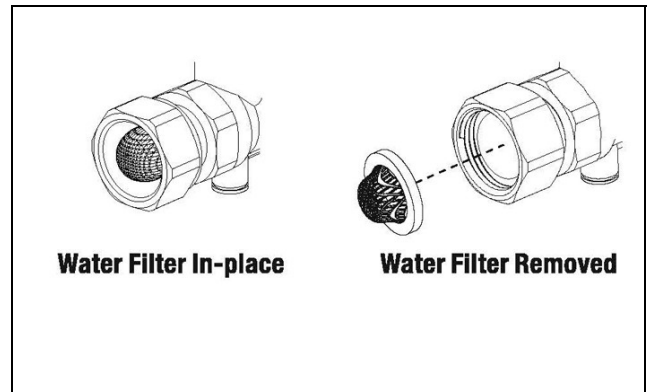

CHANGING THE SPARK PLUG



CAUTION: ALLOW THE ENGINE TO COOL BEFORE REMOVING THE SPARK PLUG.

1. Remove the spark plug cap from the spark plug.
2. Use the supplied spark plug spanner to remove the spark plug.
3. Remove any carbon that has accumulated around the spark plug.
4. Check the spark plug gap, it should be between 0.7 and 0.8 mm, adjust if necessary.
5. Check the overall condition of the spark plug and replace if necessary.
6. Reinstall the spark plug and replace the spark plug cap.

CHECKING THE AIR FILTER



CAUTION: DO NOT USE THE GENERATOR WITHOUT THE AIR FILTER FITTED, THIS CAN DAMAGE THE ENGINE.



WARNING: DO NOT USE FLAMMABLE SOLVENTS OR PETROL TO CLEAN THE AIR FILTER.

1. Remove the wingnut and remove the air filter cover.



2. Remove the second wingnut shown.



3. Remove the air filter element.

4. Make sure that the air filter is clean and not damaged.

- If the air filter is damaged contact CLARKE spare parts department for a replacement.
- If the filter is dirty, wash it in a solution of warm water and mild detergent and rinse thoroughly.

Leave the filter to dry completely; before immersing the filter in clean engine oil and squeeze the filter to remove excess oil.

5. Replace the filter and the air filter cover.



STORAGE

ENGINE

See the separate engine manual supplied, for information regarding the storage procedure.

PUMP

1. Drain all water from the high pressure hose, coil it and store it on the hose holder, located on the rear of the power washer.
2. Drain all water from the spray gun and spray wand by holding the gun/wand vertically with the nozzle pointing down, and pulling the trigger. Store in the gun holder on the side of the power washer.
3. Store all other parts so that they are protected from damage.
4. Protect the power washer from freezing conditions to prevent damage to the hoses, valves and pump.

STORAGE PROCEDURE

For long term storage, the petrol tank should be drained. Ensure that the engine is cold before draining the tank. Remove the fuel tank cap and use a pump type syphon to drain the petrol into an appropriate, clean container.

Dispose of excess petrol in an environmentally safe way. Your local recycling centre can advise you on the best method of disposal. After the petrol tank has been drained, start the engine and allow it to use any petrol that may remain in the engine or fuel pipe. Make sure that the power washer has been thoroughly cleaned before storing it in a clean dry place.

TROUBLESHOOTING

If the following does not solve your problem, please contact the CLARKE service department.

| PROBLEM | CAUSE | SOLUTION |
|---|---|---|
| Engine will not start, see engine manual for further engine troubleshooting | No fuel | Add fuel (See Page 12) |
| | Low oil | Add oil (See Page 11-12) |
| | Pressure builds up after two pulls on the recoil starter or after initial use | Squeeze the gun trigger to relieve the pressure |
| | Spark plug wire not attached correctly | Attach the spark plug wire |
| | Engine switch is in the OFF position | Set the engine switch to the ON position |
| | Choke lever is set to the choke position when the engine is warm | Set the choke lever to the NO CHOKE position (See Pages 13-15) |
| | Fuel valve closed | Open the fuel valve |
| Lack of pressure (initial use) continued | Throttle control lever is not in the fast position | Move the throttle control lever to the fast position |
| | Choke lever is in the CHOKE position | Move the choke lever to the NO CHOKE position (See Pages 13-15) |
| | High pressure hose is too long | Make sure the high pressure hose is under 100 feet |
| No or low pressure (after a period of normal use) | Worn seal | Have it replaced by your dealer |
| | Worn or obstructed valves | Have it replaced by your dealer |
| | Worn unloader piston | Have it replaced by your dealer |
| | Worn E-Z start valve | Have it replaced by your dealer |

| PROBLEM | CAUSE | SOLUTION |
|--|--|--|
| Lack of pressure (initial use) | Water supply is not adequate | Make sure your water supply can deliver 25 litres per minute at 20psi |
| | Leak in the high pressure hose fitting | Tighten the fitting, use sealant tape if required |
| | Nozzle is obstructed | Clear the nozzle (See Page 20) |
| | Water filter screen is clogged | Remove and clean the filter (See Page 18) |
| | Air in the supply hose | Turn off the engine Turn off the water supply, Disconnect the water supply from the pump inlet and turn on the water to expel the air from the hose. When all the air has been removed, turn off the water supply and reconnect the hose. Turn on the water supply and pull the trigger to expel any air in the gun/wand |
| Power washer will not draw detergents | Chemical filter is blocked | Clean the filter (See Page 20) |
| | Chemicals being used are too thick | Dilute the chemicals (The chemicals should have the consistency of water) |
| | High pressure hose is too long. | Use a longer supply hose instead of a longer high pressure hose |
| | Chemical build up inside the chemical injector | Have the parts cleaned or replaced by your dealer |
| Water leaking at the gun / spray wand connection | Worn or broken O-ring | Check and replace |
| | Loose hose connection | Tighten |
| Water leaking at the pump | Loose connections | Tighten |
| | Piston packings worn | Have it replaced by your dealer |
| | Worn or broken O-ring | Have it replaced by your dealer |
| | Pump head or tubes damaged from freezing | Have it replaced by your dealer. |

| PROBLEM | CAUSE | SOLUTION |
|-------------------------|-------------------|---------------------------------|
| Oil leaking at the pump | Oil seals worn | Have it replaced by your dealer |
| | Loose drain plug | Tighten |
| | Worn O-rings | Check and replace |
| Pump pulsates | Nozzle obstructed | Clear the nozzle (See Page 20) |

EXPLODED DIAGRAM - FRAME

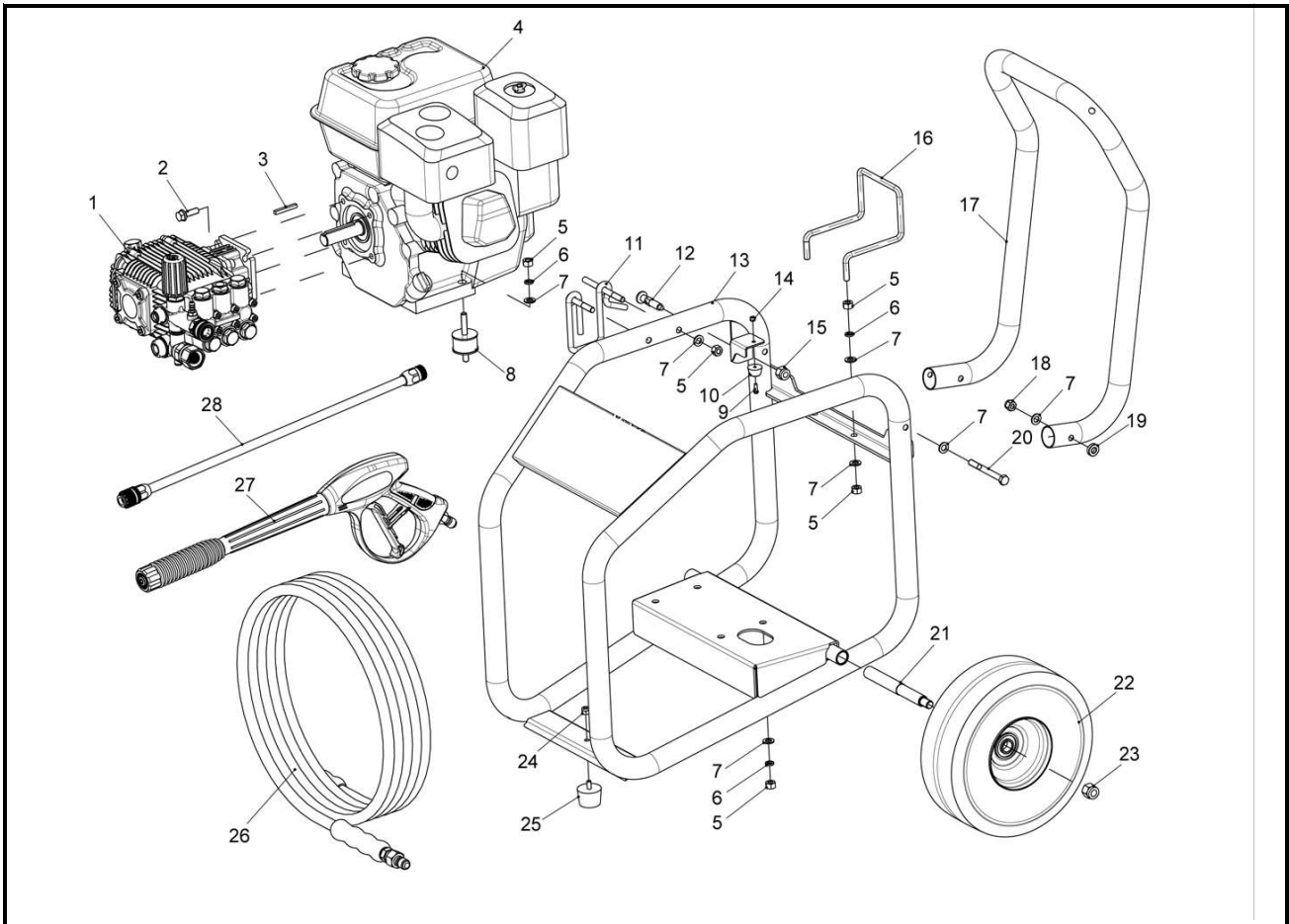

PARTS LIST- FRAME

| | |
|----|---------------------|
| 1 | Pump |
| 2 | Bolt |
| 3 | Key |
| 4 | Engine |
| 5 | Screw Nut |
| 6 | Spring Washer |
| 7 | Plain Washer |
| 8 | Rubber Foot: Engine |
| 9 | Bolt |
| 10 | Rubber Mat |
| 11 | Hook: Gun |
| 12 | Pull Pin |
| 13 | Frame Body |
| 14 | Screw Nut |

| | |
|----|--------------------|
| 15 | Screw Nut |
| 16 | Hook: Hose |
| 17 | Handle |
| 18 | Screw Nut |
| 19 | Wear Resistant Pad |
| 20 | Bolt |
| 21 | Axle |
| 22 | Wheel |
| 23 | Screw Nut |
| 24 | Screw Nut |
| 25 | Rubber Foot: Frame |
| 26 | High Pressure Hose |
| 27 | Gun |
| 28 | Lance |

EXPLODED DIAGRAM - PUMP

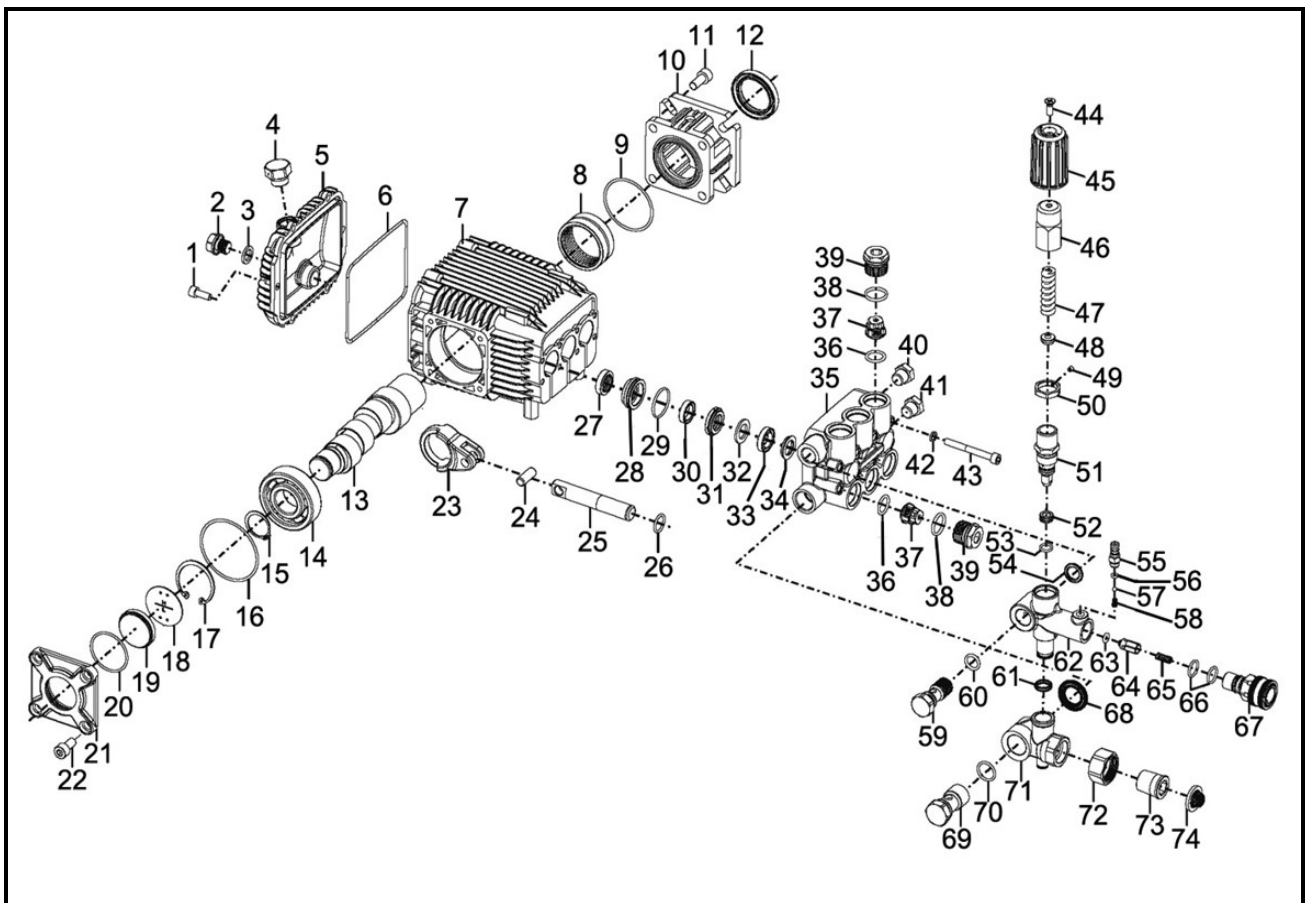

PARTS LIST- PUMP

| | |
|----|--|
| 1 | Bolt, Crankcase Cover M6 x16 |
| 2 | Oil Drain Plug |
| 3 | O-Ring, Oil Drain Plug 14.2 x 1.9 |
| 4 | Vented Oil Cap |
| 5 | Crankcase Cover |
| 6 | Gasket, Crankcase Cover, 103 x 83 x 2.65 |
| 7 | Crankcase |
| 8 | Needle Bearing |
| 9 | O-Ring, Flange 51.8 x 2.2 |
| 10 | Flange |
| 11 | Bolt, Flange 51.8 x 2.2 |
| 12 | Oil Seal, Flange |
| 13 | Crankshaft |

| | |
|----|---------------------------------------|
| 14 | Ball Bearing |
| 15 | Scrap Ring |
| 16 | O-Ring, Crankshaft Cover 55.25 x 2.62 |
| 17 | Retain Ring |
| 18 | Oil Level Plate |
| 19 | Oil Sight Glass |
| 20 | O-Ring, Oil Sight Glass 38 x 1.8 |
| 21 | Crankshaft Cover |
| 22 | Bolt, Crankshaft Cover M8 x 16 |
| 23 | Connecting Rod |
| 24 | Pin |
| 25 | Ceramic Coating Plunger |
| 26 | O-Ring,15 |

| | |
|----|---|
| 27 | Oil Seal, Plunger |
| 28 | Location Ring |
| 29 | O-Ring, Locating Ring 26.7 x 1.78 |
| 30 | Low Pressure Water Seal |
| 31 | Compression Ring |
| 32 | Compression Flake |
| 33 | High Pressure Water Seal |
| 34 | Supporting Ring |
| 35 | Manifold |
| 36 | O-Ring, Checking Valve 15.54 x 2.62 |
| 37 | Checking Valve Assembly |
| 38 | O-Ring, Valve Cap 18 x 2.4 |
| 39 | Checking Valve Cap |
| 40 | Outlet Plug, Manifold |
| 41 | Inlet Plug, Manifold & Thermal Relief Valve |
| 42 | Washer, Bolt, Manifold |
| 43 | Bolt, Manifold M6 x 55 |
| 44 | Screw, Knob Cap M6 x 10 |
| 45 | Plastic Knob Cap |
| 46 | Pressure Adjusting Knob |
| 47 | Pressure Adjusting Spring |
| 48 | Spring Seat |
| 49 | Screw, Jam Nut |
| 50 | Pressure Jam Nut |
| 51 | Unloader Valve Assembly |

| | |
|----|---|
| 52 | Valve Seat |
| 53 | O-Ring, Valve Seat 9.25 x 1.78 |
| 54 | Gasket, Unloader Valve Housing 18 x 2.4 |
| 55 | Detergent Injector Fitting |
| 56 | O-Ring, Injector Fitting 4.47 x 1.78 |
| 57 | Ball, Injector Fitting |
| 58 | Spring, Injector Fitting |
| 59 | Water outlet Banjo Bolt |
| 60 | O-Ring, Outlet Banjo Bolt 12.2 x 2.4 |
| 61 | O-Ring, Unloader Valve Housing 11.3 x 2.4 |
| 62 | Unloader Valve Housing |
| 63 | O-Ring, Outlet Checking Valve 4.2 x 2.4 |
| 64 | Outlet Checking Valve |
| 65 | Spring, Outlet Checking Valve |
| 66 | O-Ring, Outlet Fitting 14 x 1.9 |
| 67 | Quick Disconnect Outlet Fitting |
| 68 | Gasket, Bypass Housing |
| 69 | Water Inlet Banjo Bolt |
| 70 | O-Ring, Inlet Banjo Bolt 16.3 x 2.4 |
| 71 | Bypass Housing |
| 72 | Swivel Nut, Inlet Connector |
| 73 | Body, Inlet Connector |
| 74 | Filter Washer, Inlet Connector |
| | |
| | |

DECLARATION OF CONFORMITY



DECLARATION OF CONFORMITY

This is an important document and should be retained.

We hereby declare that this product(s) complies with the following legislation: The following standards have been applied to the product(s):

Noise Emission in the Environment by Equipment for use Outdoors Regulations 2001

IEC 62321-4:2013+AMD1:2017, EN 1679-1:1998+A1:2011, EN 55012:2007+A1:2009,

The Electromagnetic Compatibility Regulations 2016

EN 60335-2-79:2012, IEC 62321-7-1:2015, IEC 62321-7-2:2017, EN ISO 12100:2010,

The Supply of Machinery (Safety) Regulations 2008

EN ISO 3744:2010, IEC 62321-5:2013, IEC 62321-6:2015, IEC 62321-8:2017

The Restriction of the Use of Certain Hazardous Substances in Electrical and Electronic Equipment Regulations 2012

The technical documentation required to demonstrate that the product(s) meet(s) the requirement(s) of the aforementioned legislation has been compiled and is available for inspection by the relevant enforcement authorities.

The UKCA mark was first applied in: 2023

| | | | |
|-----------------------------|---|------------------------------|--|
| Manufacturer: | Clarke International Ltd, Hemnall Street, Epping, Essex, CM16 4LG, United Kingdom | Notified Body: | N/A |
| Product Description: | Pressure Washer | Assessment Procedure: | Annex V of above noise legislation |
| Model Number(s): | PLS220 | Measured LWA: | 93.37 dB |
| Serial/Batch Number: | Refer to product/packaging label | Guaranteed LWA: | 94 dB |
| Document Holder: | Alan Pond | Signed: |  J.A. Clarke Director |
| Date of Issue: | 20/12/2023 | | |

PLS220 UKCA Clarke DOC 122023

Page 1 of 1

DECLARATION OF CONFORMITY



DECLARATION OF CONFORMITY

This is an important document and should be retained.

We hereby declare that this product(s) complies with the following legislation: The following standards have been applied to the product(s):

| | | |
|------------|---|--|
| 2000/14/EC | <i>Outdoor Noise Directive</i> | IEC 62321-4:2013+AMD1:2017, EN 1679-1:1998+A1:2011, EN 55012:2007+A1:2009, |
| 2014/30/EU | <i>Electromagnetic Compatibility Directive</i> | EN 60335-2-79:2012, IEC 62321-7-1:2015, IEC 62321-7-2:2017, EN ISO 12100:2010, |
| 2006/42/EC | <i>Machinery Directive</i> | EN ISO 3744:2010, IEC 62321-5:2013, IEC 62321-6:2015, IEC 62321-8:2017 |
| 2011/65/EU | <i>Restriction of Hazardous Substances (RoHS) Directive</i> | |

The technical documentation required to demonstrate that the product(s) meet(s) the requirement(s) of the aforementioned legislation has been compiled and is available for inspection by the relevant enforcement authorities.

The CE mark was first applied in: 2020

| | | | |
|-----------------------------|--|------------------------------|---|
| Manufacturer: | Clarke International Ltd, Fitzwilliam Hall, Fitzwilliam Place, Dublin 2, Republic of Ireland | Notified Body: | N/A |
| Product Description: | Pressure Washer | Assessment Procedure: | Annex V of above noise legislation |
| Model Number(s): | PLS220 | Measured LWA: | 93.37 dB |
| Serial/Batch Number: | Refer to product/packaging label | Guaranteed LWA: | 94 dB |
| Document Holder: | Alan Pond | Signed: |  J.A Clarke |
| Date of Issue: | 20/12/2023 | | Director |

PLS220 CE Clarke DOC 122023

Page 1 of 1

A SELECTION FROM THE VAST RANGE OF

Clarke®

QUALITY PRODUCTS



AIR COMPRESSORS

From DIY to industrial, Plus air tools, spray guns and accessories.

GENERATORS

Prime duty or emergency standby for business, home and leisure.

POWER WASHERS

Hot and cold, electric and engine driven - we have what you need

WELDERS

Mig, Arc, Tig and Spot. From DIY to auto/industrial.

METALWORKING

Drills, grinders and saws for DIY and professional use.

WOODWORKING

Saws, sanders, lathes, mortisers and dust extraction.

HYDRAULICS

Cranes, body repair kits, transmission jacks for all types of workshop use.

WATER PUMPS

Submersible, electric and engine driven for DIY, agriculture and industry.

POWERTOOLS

Angle grinders, cordless drill sets, saws and sanders.

STARTERS/CHARGERS

All sizes for car and commercial use.

PARTS & SERVICE: 0208 988 7400

Parts Enquiries
Parts@clarkeinternational.com

Servicing & Technical Enquiries
Service@clarkeinternational.com

SALES: UK 01992 565333 or Export 00 44 (0)1992 565335

Clarke INTERNATIONAL Hemnall Street, Epping, Essex CM16 4LG
www.clarkeinternational.com